

Shell and Tube Heat Exchangers

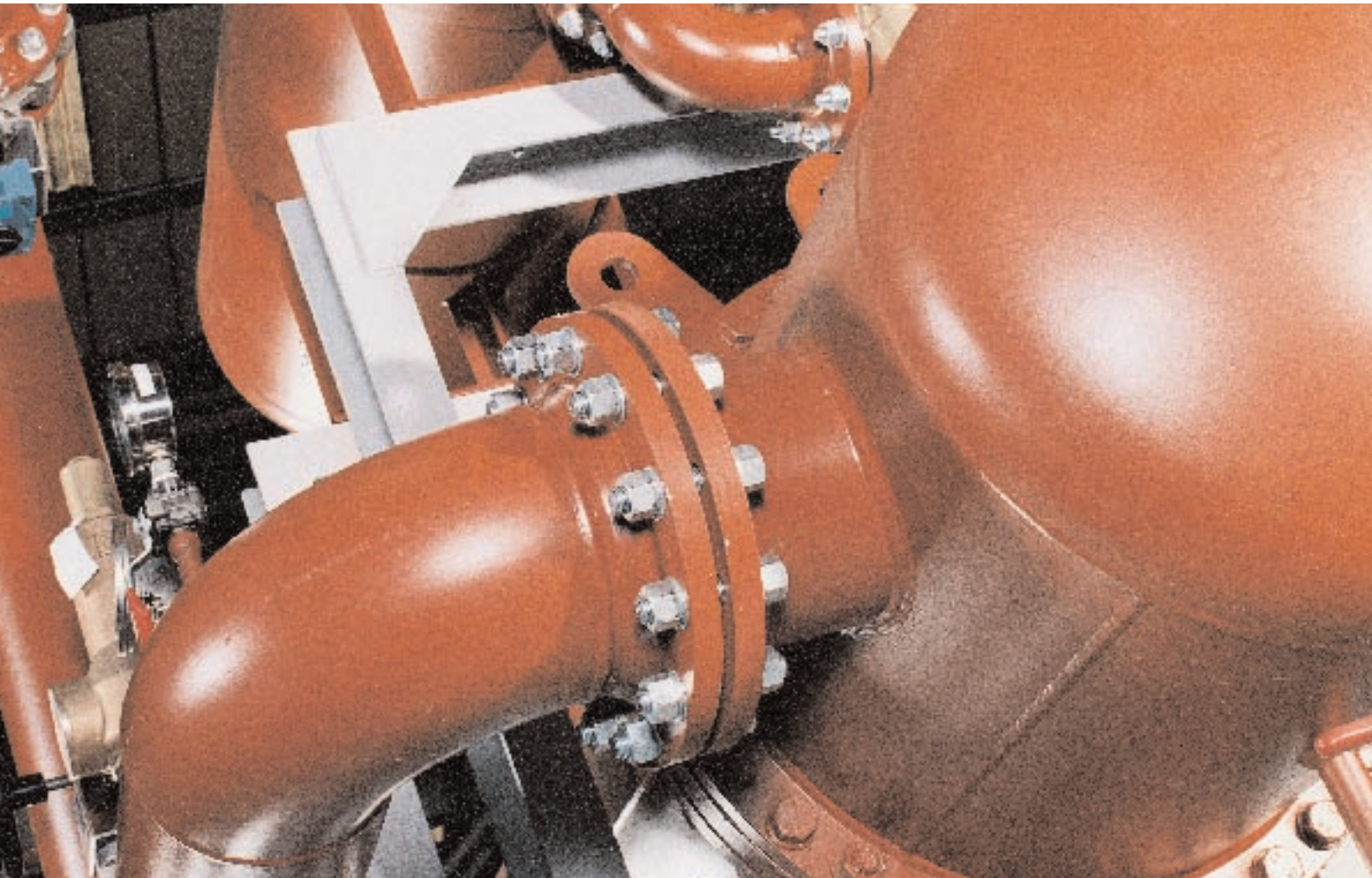

Shell and Tube Heat Exchangers

THE RYCROFT RANGE OF NON-STORAGE HEATING CALORIFIERS HAVE BEEN DESIGNED TO MEET THE REQUIREMENTS OF TODAY'S ENVIRONMENT AND ARE SUITABLE FOR WATER TO WATER AND STEAM TO WATER APPLICATIONS. RYCROFT ALSO MANUFACTURE A RANGE OF SEMI-PACKAGE UNITS, FULLY-PACKAGED UNITS AND CONDENSATE PUMPING SETS.

Construction

The NSZ range have welded mild steel shells, cast iron chests and copper 'U' tubes. The shells, chests and the heater batteries are designed in accordance with BS 853 with extended surface integron tube for efficient and compact units. The tubes are expanded into steel tubeplates under electronic control to ensure even expansion. Batteries are adequately supported to prevent tube vibration and in the larger sizes a roller is provided to assist withdrawal. In many cases the heaters are baffled for increased performance. Mild steel chests are used when the design pressure exceeds 10 bar, the primary inlet temperature exceeds 120°C or the size of primary connection necessitates it.

Design Factors

A corrosion allowance of at least 2 mm is included in the shell thickness. An overall fouling factor of 0.176 sq. m C/kW is incorporated which is equivalent to at least 10% extra surface for a clean unit. In a closed heating system the degree of fouling is minimal but if the secondary water is known to precipitate heavy scale additional heating surface is advisable.

Accessories

Connections are provided to accommodate a safety valve, thermometer, pressure gauge, drain cock and secondary vent. Thermostatic control elements should be inserted into the secondary flow pipeline. A bursting disc can be fitted if required. All mountings and controls can be supplied by Rycroft. Factory fitted insulation can also be supplied.

Non-Standards

There are occasions when other materials than those listed are necessary: for example copper, galvanised mild steel or stainless steel shells may be required to resist corrosive water and these can be supplied together with suitable batteries. Where severe scaling is expected and facilities do not exist for chemical de-scaling, there is good reason to use plain tube copper batteries. However, this invariably necessitates a larger unit.

Selection

Sizing data exists for standard units on software running on an IBM compatible PC operating under MS-DOS Version 3 or higher. Floppy disks are available upon request.

Points to remember when specifying non-storage heating calorifiers

- Type of fixing – Vertical or Horizontal.
- Duty required in kW or litres/sec.
- Primary and secondary temperatures.
- Steam conditions after the control valve.
- Working head or test pressure on the secondary side.
- Maximum working pressure on the primary side.
- Details of connections and mountings.
- Any special circumstances or regulations affecting the installation.



Water to Water Non-Storage Calorifiers

Limiting Conditions
BS 853 Part 1

	Shell	Tubes	C.I. Chest	M.S. Chest
Maximum Design Pressure (Bar)	7.7	17.5	10	17.5
Maximum Test Pressure (Bar)	11.5	26.25	15	26.25

Limiting Conditions
BS 853 Part 2

	Shell	Tubes	M.S. Chest
Maximum Design Pressure (Bar)	20	20	20
Maximum Test Pressure (Bar)	30	30	30

The Maximum Design Pressures are listed as a guide only. The required design or maximum working pressure must be specified at the enquiry stage.

STANDARD CONNECTIONS

A Primary Flow	F Safety Valve
B Primary Return	G Vent
C Secondary Flow	H Thermometer
D Secondary Return	J Drain
E Pressure Gauge	K Lifting Lugs

Water to Water Non-Storage Tabulation

Unit	A	B	C	D	E	F	G	H	J	K	A&B	C&D	F	G	Mass (kg)				
	(mm)										Connections (mm)								
1009	100	900	970	190	125	125	250	75	100	825	Sized to suit Primary Flow Rate	40	Sized to the requirements of BS 853	32	27				
1012		1200	1270							1125								32	
1015		1500	1570							1425								37	
1509	150	900	970	245	125	125	250	75	100	850						65		32	49
1512		1200	1270							1150								58	
1515		1500	1570							1450								68	
2009	200	900	985	330	125	125	200	150	100	875						65		40	85
2012		1200	1285				250			1175								100	
2015		1500	1585				250			1475								116	
2509	255	850	950	395	150	150	150	150	100	750						100		50	118
2512		1150	1250				250			1050								135	
2515		1450	1550				250			1350								154	
2518		1750	1850				250			1650								176	
3009	305	950	1065	445	175	175	200	150	100	925						125		50	174
3012		1250	1365				250			1225								206	
3015		1550	1665				250			1525								237	
3018		1850	1965				250			1825								271	
3812	380	1150	1285	520	175	250	250	230	100	1125						150		65	280
3815		1450	1585				250			1425								328	
3818		1750	1885				250			1725								380	
3821		2050	2185				400			2025				428					
4512	455	1200	1370	595	175	250	250	230	100	1150		150		65	420				
4515		1500	1670				250			1450				488					
4518		1800	1970				250			1750				564					
4521		2100	2270				400			2050				632					
4524		2400	2570				400			2350				700					
5012	510	1200	1375	645	200	275	250	230	100	1175		200		65	462				
5015		1500	1675				250			1475				545					
5018		1800	1975				250			1775				628					
5021		2100	2275				400			2075				711					
5024		2400	2575				400			2375				795					
5027		2700	2875				400			2675				876					

Sizing data is available on disk

Steam to Water Non-Storage Calorifiers

STANDARD CONNECTIONS

A Steam	F Safety Valve
B Condensate	G Vent
C Secondary Flow	H Thermometer
D Secondary Return	J Drain
E Pressure Gauge	K Lifting Lugs

N.B. All connections up to 50mm (2 in) screwed unless otherwise requested.

Limiting Conditions

BS 853 Part 1	Shell	Tubes	C.I. Chest	M.S. Chest
Maximum Design Pressure (Bar)	7.7	17.5	10	17.5
Maximum Test Pressure (Bar)	11.5	26.25	15	26.25

Limiting Conditions

BS 853 Part 2	Shell	Tubes	M.S. Chest
Maximum Design Pressure (Bar)	20	20	20
Maximum Test Pressure (Bar)	30	30	30

The Maximum Design Pressures are listed as a guide only. The required design or maximum working pressure must be specified at the enquiry stage.

Steam to Water Non-Storage Tabulation

Unit	A	B	C	D	E	F	G	H	J	K	A&B	C&D	F	G	Mass (kg)									
	(mm)										Connections (mm)													
1009	100	900	970	190	125	125	250	75	300	825	Sized to suit Primary Flow Rate	40	Sized to the requirements of BS 853	32	27									
1012		1200	1270							1125								32						
1015		1500	1570							1425								37						
1509	150	900	970	245	125	125	250	75	300	850					65		32	49						
1512		1200	1270							1150											58			
1515		1500	1570							1450											68			
2009	200	900	985	330	125	125	200	150	300	875								65		40	85			
2012		1200	1285				250			1175														100
2015		1500	1585				250			1475														116
2509	255	850	950	395	150	150	150	150	300	750								100		50	118			
2512		1150	1250				250			1050														135
2515		1450	1550				250			1350														154
2518		1750	1850				250			1650														176
3009	305	950	1065	445	175	175	200	150	300	925					125		50				174			
3012		1250	1365				250			1225														206
3015		1550	1665				250			1525														237
3018		1850	1965				250			1825														271
3812	380	1150	1285	520	175	250	250	230	300	1125											150		65	280
3815		1450	1585				250			1425														
3818		1750	1885				250			1725								380						
3821		2050	2185				400			2025				428										
4512	455	1200	1370	595	175	250	250	230	300	1150	150		65	420										
4515		1500	1670				250			1450							488							
4518		1800	1970				250			1750							564							
4521		2100	2270				400			2050							632							
4524		2400	2570				400			2350							700							
5012	510	1200	1375	645	200	275	250	230	300	1175				200		65	462							
5015		1500	1675				250			1475										545				
5018		1800	1975				250			1775										628				
5021		2100	2275				400			2075							711							
5024		2400	2575				400			2375							795							
5027		2700	2875				400			2675							876							

Sizing data is available on disk

Steam to Water Semi-Packaged and Packaged Units

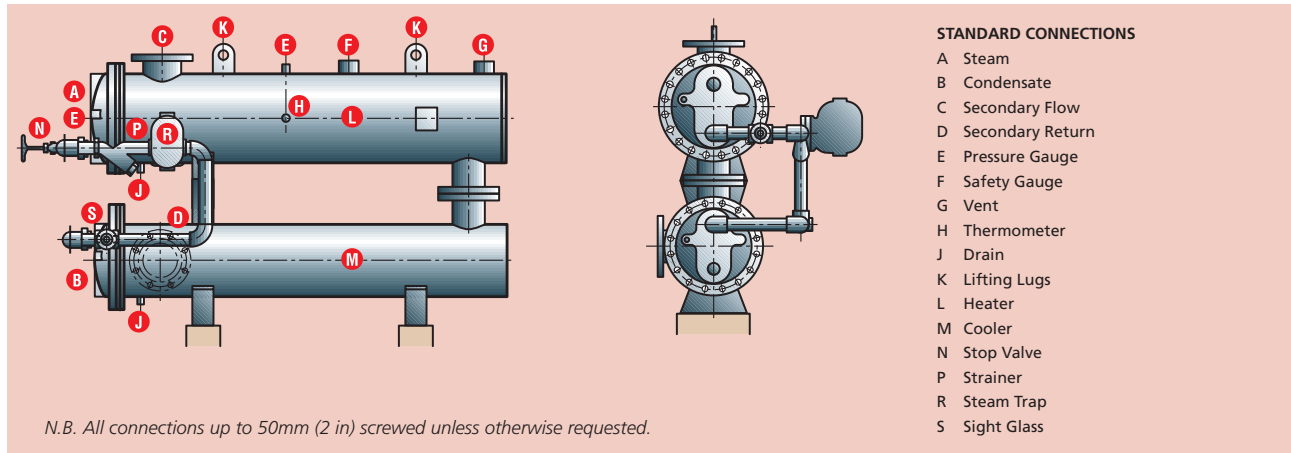

Semi-Packaged Units

The Rycroft range of semi-package units are factory assembled and consist of a steam heating calorifier, condensate cooler, steam trap, sight glass, stop valve and strainer. The semi-package unit offers a very efficient method of recovering waste heat from the condensate. It both removes flash and cools the condensate assuming the secondary temperatures are below 100°C. A condensate pump is required to feed the condensate back to the boiler plant unless the layout provides a gravity return.

Limiting Conditions BS 853 Part 1

	Shell	Tubes	C.I. Chest	M.S. Chest
Maximum Design Pressure (Bar)	7.7	17.5	10	17.5
Maximum Test Pressure (Bar)	11.5	26.25	15	26.25

Limiting Conditions BS 853 Part 2

	Shell	Tubes	M.S. Chest
Maximum Design Pressure (Bar)	20	20	20
Maximum Test Pressure (Bar)	30	30	30

The Maximum Design Pressures are listed as a guide only. The required design or maximum working pressure must be specified at the enquiry stage.

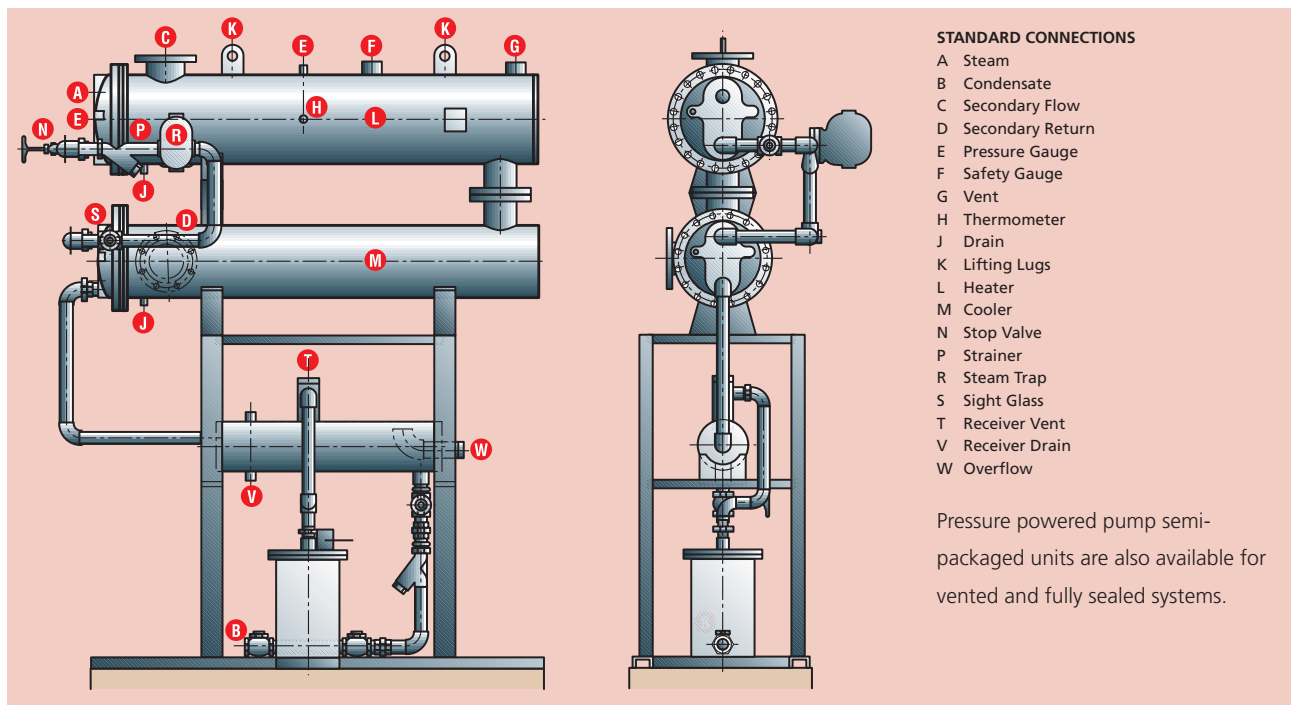

Packaged Units

The Rycroft range of fully packaged units offers the most efficient way of utilising waste heat from condensate. The unit includes steam calorifier, condensate cooler, steam trap, strainer, sight

glass, mechanical pump and pump receiver ensuring that the flash steam is turned to useful heat and the condensate is pumped back to the boiler plant.

Condensate Pumping Sets

THE RYCROFT RANGE OF CONDENSATE PUMPING SETS IS SUPPLIED FULLY PACKAGED, COMPRISING A HORIZONTAL RECEIVER MOUNTED ON A MILD STEEL SUPPORT FRAME. STANDARD UNITS ARE SUPPLIED WITH DUTY AND STANDBY PUMPS, PIPEWORK TO THE INLET ON EACH PUMP, ISOLATING VALVES ON THE SUCTION SIDE AND CHECK VALVES ON THE DISCHARGE SIDE. STARTERS AND LEVEL CONTROLS ARE PRE-WIRED AND TESTED. LIQUID LEVEL SIGHT GLASS AND RECEIVER DRAIN COCK ARE FITTED AS STANDARD.

- Receivers are available in copper, galvanised mild steel or stainless steel.
- Duplicate vertical/horizontal end suction centrifugal pumps with 3 phase, 415V, 50Hz motors.
- Low-high and extra high liquid level control with 4 probe liquid level sensing unit.
- Designed to handle and pump condensate up to 95°C with higher temperatures available if required.

Electrical Specification

Automatic changeover pump and liquid level control system comprising:

- Pressed steel I.P. 55 enclosure.
- Door interlock isolator switch.
- Three position selector switch for manual or auto changeover pump selection.
- Power on lamp.
- Power run lamp.
- Pump trip lamp.
- Seven day time switch for pump changeover sequencing.
- Pump contactors, overloads and auto changeover relays.
- 415V to 110V x 50VA control circuit transformer.
- High sensitivity, relay output liquid level switches for low-high and extra high liquid level control.
- 4 probe liquid level sensing unit for low-high and extra high liquid level for cascade switching of pumps.
- Volt-free contacts for user remote alarm facility.
- All necessary fuses, terminals and inter-connecting wiring.
- Wiring external to enclosure to be in flexible PVC conduit.

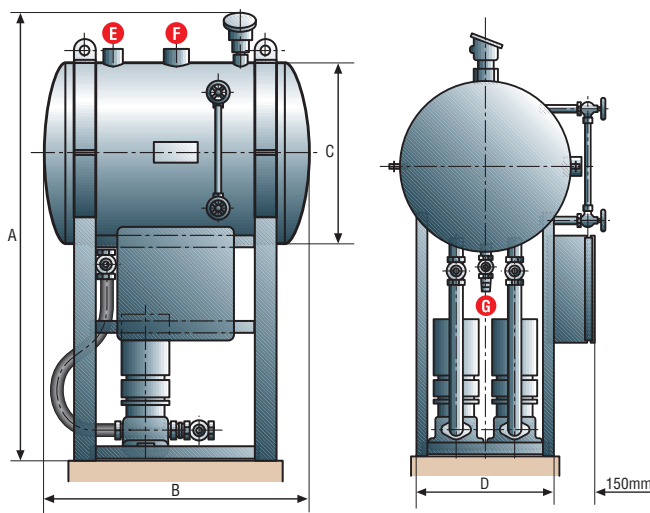

Dimensions

Unit	Dimensions				Connections (mm)			Pump Discharge	Motor Power
	A	B	C	D	E Inlet	F Vent and Overflow	G Drain	Screwed BSP Female	kW
PS 1651	1720	900	500	400	40	50	15	25	0.37
PS 1652	1720	900	500	400	40	50	15	25	0.37
PS 1653	1720	900	500	400	40	50	15	25	0.55
PS 3001	1830	1200	600	500	50	50	15	25	0.37
PS 3002	1830	1200	600	500	50	50	15	25	0.55
PS 3003	1830	1200	600	500	50	50	15	25	0.75
PS 3851	1860	1500	600	500	65	65	20	40	0.75
PS 3852	1860	1500	600	500	65	65	20	40	1.1
PS 3853	1860	1500	600	500	65	65	20	40	1.5
PS 5001	1980	1325	750	520	80	80	20	50	2.2
PS 5002	1980	1325	750	520	80	80	20	50	3.0
PS 6501	2150	1370	850	650	100	100	20	50	2.2
PS 6502	2150	1370	850	650	100	100	20	50	3.0

Replacement U-Tube Bundles

RYCROFT CAN PROVIDE REPLACEMENT TUBE BUNDLES FOR MOST CALORIFIERS IRRESPECTIVE OF THE ORIGINAL MANUFACTURER. WHERE THE ORIGINAL TYPE OF TUBE IS NO LONGER AVAILABLE, OUR DESIGN DEPARTMENT CAN OFTEN OFFER AN ALTERNATIVE ARRANGEMENT.

The following materials are available:

Tube:

- Copper low fin tube
- Copper plain tube
- Stainless Steel low fin tube 304 and 316
- Stainless Steel plain tube 304 and 316
- Copper Nickel low fin tube 90/10 and 70/30
- Copper Nickel plain tube 90/10 and 70/30
- Aluminium Bronze
- Aluminium Brass

Flange:

- Carbon steel
- Brass 70/30
- Brass 60/40
- Naval Brass
- Stainless Steel 304 and 306
- Copper Nickel 90/10 and 70/30
- Aluminium Bronze
- Aluminium Brass







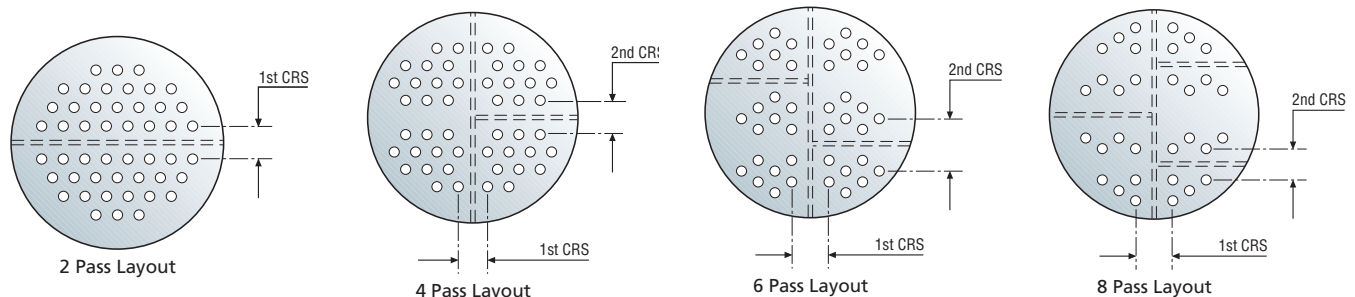
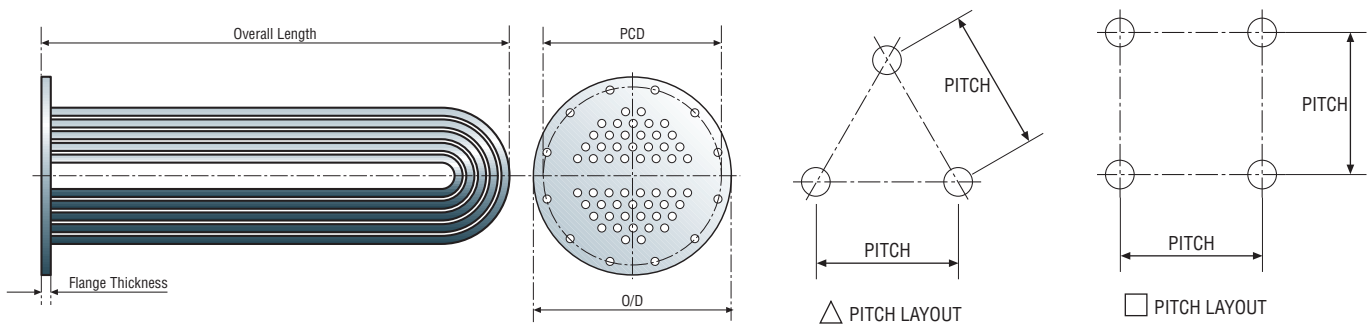

The following information is required when specifying replacement tube bundles:

Outside flange diameter	Number of tube holes	Bolt pitch circle diameter
Flange thickness	Diameter of tube	Bolt hole circle diameter
Raised face diameter and thickness	Type of tube	Number of bolts
Flange material	Number of baffles	Size of bolts
Tube material	Type of baffles (half, quarter, etc.)	Bolts on/off centre
Baffle material	Pitch type	Number of passes
Maximum operating pressure	Pitch centres	Pass centres
Maximum operating temperature		Overall length

Extras (if required)

- Collar bolts
- Runner wheels
- Starting screws
- Lifting eyes
- Spare gaskets



-  SUPAPAC Plate Heat Exchangers
-  Shell and Tube Heat Exchangers
-  COMPAC Plate Heat Exchanger Packages
-  MAXIMISER Semi-Storage Calorifiers
-  Calorifiers/Cylinders
-  Unvented Packages
-  Pressurisation
-  Electric Water Heaters
-  Rycroft Process Solutions

Airtrend Limited
 27 Eyre Court
 Finchley Road
 London NW8 9TT, UK
 Tel: ++ 44 20 77224277
 Fax: ++ 44 20 75867357
 E-mail: airtrend@airtrend.co.uk
 Web: www.airtrend.co.uk

Airtrend Limited
 Representative office
 Kumanovska 14
 11000 Belgrade, Serbia
 Tel: +381 11 383 68 86
 Fax: +381 11 344 41 13
 E-mail: gobrid@eunet.rs
 Web: www.airtrend.rs



Rycroft
 HEATING THE WORLD'S WATER

